

Type Q3T 315 MX2

Cod. R315021600B3B5G0000T

Mounting position

IM	B3
IM	1001

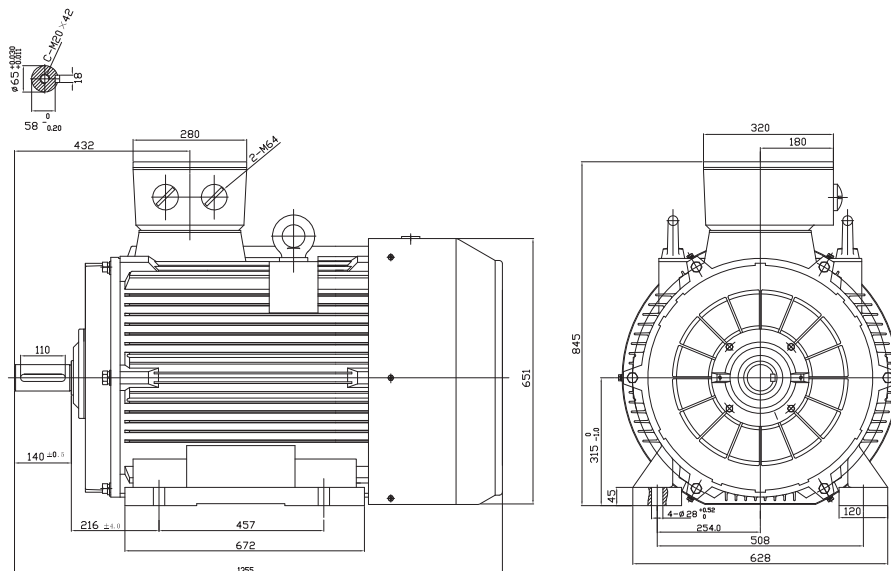

Electrical data			
Rated motor power	160		Kw
Rated motor speed	2960		min ⁻¹ 50Hz
	3555		min ⁻¹ 60Hz
Rated motor frequency	50		Hz
Rated motor voltage(+/-10%)	400		VΔ/50Hz
	690		VY/50Hz
	480		VΔ/60Hz
	830		VY/60Hz
Rated motor torque	516.2		Nm (Mn)
	267.8	VΔ/50Hz	A (In)
Rated motor current	154.8	VY/50Hz	A (In)
	7		xIn
Starting motor torque	2		xMn
Breakdown motor torque	2.3		xMn
Starting			D.O.L.
Efficiency class	IE3		
Efficiency	50Hz	60Hz	
	95.8	-	100% load
	95.8	-	75% load
	94,5	-	50% load
Power factor cosφ	0.9	0.9	100% load

General data			
Frame size	315		
Mounting	B3		
Weight	1155		Kg
Casing material	Cast iron		
Protection	IP		55
Insulation class/Temperature rise	F	/	B
Tropicalization	Yes		
Vibration class	N		
Duty	S1		
Direction of rotation	Bidirectional		
Method of cooling	IC		411
Cable entry	2-M63x1,5+1M16x1,5		
Standards	IEC/DIN/ISO/VDE/EN		
Execute at Standard	IEC 60034-1		
Feet removable	No		
Paintwork	RAL	7024	dark grey
Thermal protections	n/a		

Site conditions	
Ambient temperature	from -20°C to +40°C
Altitude above sea level	1000 m

Mechanical data						
Noise level	LpA	80	dB(A)	Bearing DE side	6317-C3	
	LwA	90	dB(A)	Bearing NDE side	6317-C3	
Moment of inertia	2.19758		Kgm ²	Average bearing lifetime	40000 h	
Bearings type			NSK	Relubrication interval L1 DE bearing	3200 h	
Lubricants for bearings	See installation and maintenance manual page 12			Relubrication interval L1 NDE bearing	3200 h	
				Compensation ring		NDE SIDE standard