



# BEHNCKE

## Three Phase Squirrel Cage Induction Motor

Motor type Q2EPC63M4A40



### Electrical Data

RATED VALUES						STARTING VALUES				BREAKDOWN	EFFICIENCY			EFFICIENCY CLASS	
VOLTAGE	POWER		SPEED	CURRENT	TORQUE	Cos φ	CURRENT		TORQUE		TORQUE	%			IEC 60034-30-1
	V	kW	Hz	rpm	A	Nm	4/4	Y	D	Y	D	Mk/ Mn	4/4	3/4	
230/400	0,12	50	1420	0,86/0,5	0,85	0,56	3,4	-	2,2	-	3,2	IE2-59,1%	54,1	44,9	IE2
265/460	0,14	60	1740	0,76/0,44	0,76	0,53	3,3	-	2,1	-	3,1	-	-	-	

### Mechanical Data

Bearing DE	6201-ZZ	Color	RAL 6011
Bearing NDE	6201-ZZ	Motor protection	No
Lubricants	Shell Gadus S2 V100Q2	Method of cooling	IC 411
Condensation drain hole	No	Terminal box position	Top
External earthing terminal	Yes	Material of terminal box	Aluminium
Vibration class	A	Terminal plate thread	M4
Insulation Class	F	Cable gland	1xM20
Duty type	S1	Clamping range	10-14 mm
Direction of rotation	Clockwise	Mounting type	IM 2101 (B34-A)
Housing material	Aluminium		
Type of balancing	Half Key		

### Environmental Data

### Others

Ambient Temperature	-20 / + 40 °C	Type of protection	IP 55
Altitude above sea level	1000 m	Sound Pressure Level 50/60Hz	dBA 41/44
		Inertia moment (kg.mm <sup>2</sup> )	0,00022
		Standard	IEC 60034-1
		Weigh (Kg)	5,2

### Dimensions

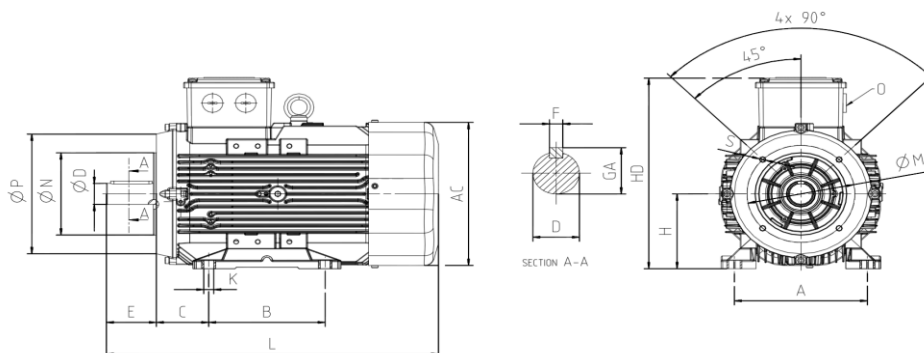

Main Dimensions		Foot Mounted Motors						Shaft				Flange Mounted Motors			
AC	L	B	A	H	HD	K	C	D	E	GA	F	P	N	M	S
123	220	80	100	63	162	7	40	11	23	12,5	4	90	60	75	M5